

OCT 03 2016

SHELLEY DICKERSON
COUNTY CLERK
160639

SA&I 1-4040 (2000)

Canadian _____ County, Oklahoma
COUNTY PURCHASING OFFICE
Canadian _____ County Court House
El Reno _____, Oklahoma
Phone: (405) 422-2441

INVITATION TO BID

PLEASE REVIEW TERMS AND CONDITIONS ON REVERSE
SIDE RELATING TO SUBMISSION OF THIS BID.
Notarized Affidavit completions and signature required on reverse side.

DATE ISSUED
October 3, 2016
Page 1 of 2

BID NUMBER Generators / #2017-#04 County Commissioners	BID CLOSING DATE AND HOUR October 21, 2016 at 4:00 pm	REQUIRED DELIVERY DATE SEE SPECIFICATIONS _____ Days after award of Purchase Order
---	--	--

TERMS Net, FOB this bid will open October 24, 2016 at 9:30am	DATE OF DELIVERY: SEE SPECIFICATIONS
---	---

ITEM	QUANTITY	UNIT OF ISSUE	DESCRIPTION	UNIT PRICE	TOTAL
1 or more			<p>Canadian County Commissioners are soliciting bids for generators to provide emergency power.</p> <p>SEE SPECIFICATIONS ATTACHED:</p> <p>The Board of Canadian County Commissioners reserves the right to reject any and all bids or to award all or any portion of the items bid. All data will be considered in the awarding of the bid including the delivery time.</p> <p><u>The reverse of this sheet must be completed and returned or the bid will be rejected.</u></p> <p>Contact person: John Johnson, Chief of Staff 201 N. Choctaw El Reno, OK 73036 (405) 295-6201</p>		<p>\$ _____ Option 1</p> <p>\$ _____ Option 2</p> <p>\$ _____ Option 3</p>

APPROVED

Date: 9-30-16

David Anderson
Officer or Department Head

2016-11-24 10:00 AM

2105 4 9 100

TERMS AND CONDITIONS

1. Sealed bids will be opened in the Commissioner's Conference Room, Canadian County Courthouse, 201 N. Choctaw Avenue, El Reno, Oklahoma, at the time and date shown on the invitation to bid form.
2. Late bids will not be considered. Bids must be received in sealed envelopes (one to an envelope) with bid number and closing date written on the outside of the envelope.
3. Unit prices will be guaranteed correct by the bidder.
4. Firm prices will be F.O.B. destination.
5. Purchases by Canadian County, Oklahoma, are not subject to state or federal taxes.
6. This bid is submitted as a legal offer and any bid when accepted by the County constitutes a firm contract.
7. Oklahoma laws require each bidder submitting a bid to a county for goods or services to furnish a notarized sworn statement of non-collusion. A form is supplied below.
8. Bids will be firm until 11/24/2016
(DATE)

AFFIDAVIT: I, the undersigned, of lawful age, being first duly sworn on oath say that he (she) is the agent authorized by the bidder to submit the above bid. Affiant further states that the bidder has not been a party to any collusion among bidders in restraint of freedom of competition by agreement to bid at a fixed price or to refrain from bidding; or with any state official or employee as to quantity; quality or price in the prospective contract or any other terms of said prospective contract; or in any discussions between bidders and any state official concerning exchange of money or other thing of value for special consideration in the letting of a contract; that the bidder/contractor has not paid, given or donated or agreed to pay, give or donate to any officer or employee of the State of Oklahoma (or other entity) any money or other thing of value, either directly or indirectly in the procuring of the award of a contract pursuant to this bid.

Subscribed and sworn before this _____ day

of _____, 20 _____

(SEAL)

Firm: _____

My commission expires _____

Signed by: _____ Title: _____
(Manual Signature of Undersigned)

NOTARY PUBLIC (CLERK OR JUDGE)

Address: _____ Phone: _____

City: _____ State: _____

Zip: _____

Please mail sealed bids to:
 Canadian County Clerk's Office
 Attn: Purchasing
 PO Box 458
 El Reno, OK 73036

Street Address:
 201 N Choctaw Avenue
 El Reno, OK 73036



Date Issued: October 3, 2016
Bid Number: **2017-#04**
Closing Date: October 21, 2016 at 4:00pm
PO Box 458, 201 N. Choctaw Ave., El Reno, OK 73036
Opening Date: October 24, 2016 at 9:30am
Commissioner's Meeting Room, 201 N. Choctaw Ave., El Reno, OK 73036

~ SPECIFICATIONS ~

Generators / County Commissioners

The Canadian County Commissioners are soliciting bids for generators to provide emergency power to the following locations:

- County Judicial Building
- County Assessor's Building

Generator(s) will be powered by diesel fuel and will be mounted on a self-contained fuel tank with a capacity to run twenty four (24) hours. All necessary switch gear and components for operation shall be included in the bid.

Contractor will be responsible for all labor, lifting devices, utility locating, boring, concrete, asphalt tear-out and replacement, mounting pads, and all electrical supplies. The multiple meter bases on the Assessor's building shall be consolidated into one new meter base as an integral part of this project.

Generator(s) will also be provided with a lockable sound enclosure.

All bids will state the length of warranty and components covered.

All bids will be priced for the following three options.

Option 1:

- County Judicial Courthouse (250 Kw 277/480-volt)
400A 277/480-VOLT N3R SE ATS

Option 2:

- County Assessor's Office (150 Kw 120/208-volt)
600A 120/208-VOLT N3R SE ATS

Option 3:

- County Judicial Courthouse (250 Kw 277/480-volt) and

- County Assessors Building (150 Kw 120/208-volt)

For Information Contact:

John Johnson, Chief of Staff

Phone: (405) 295-6201

Hours: Monday – Friday 8:30am to 4:00pm

Address: 201 N. Choctaw, El Reno, OK 73036

If you have any questions or need additional information, please contact:
Lindsey Garrett, Purchasing Agent, 405.295.6125 or 405.422.2441
lgarrett@okcana.cogov.net

ASSESSORS OFFICE
200 N. CHOCTAW AVE.
ONE LINE

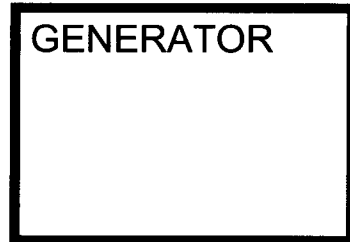

OVER HEAD
SERVICE

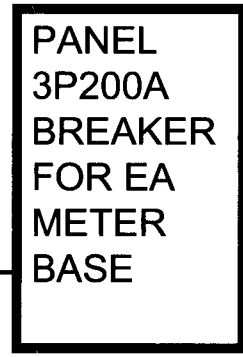
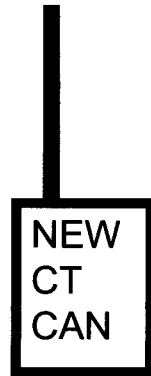

EXISTING

PROPOSED

Assessors
Offices
200 N. CHOCTAW AVE.

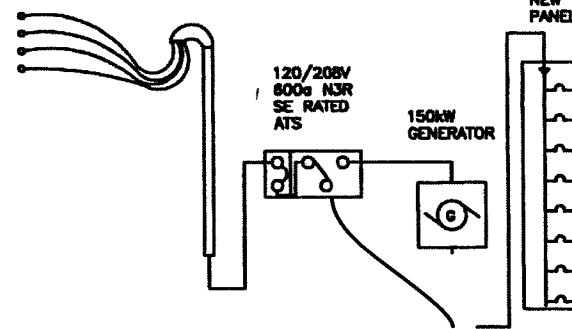
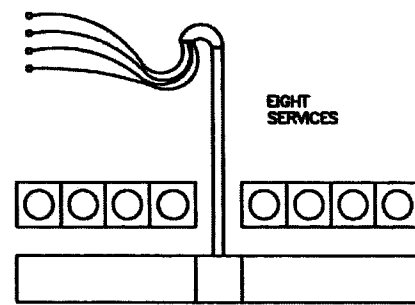

3P4W 120/208-VOLT
600A 3 pole main
breaker
8-3p200-amp breakers
Nema 3R Cabinets
connect breakers to
existing services

Judicial
Courthouse
301 N. CHOCTAW AVE.

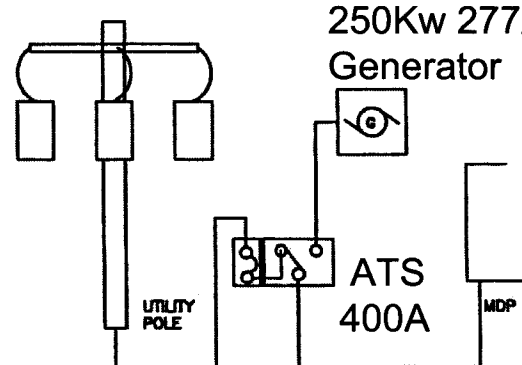
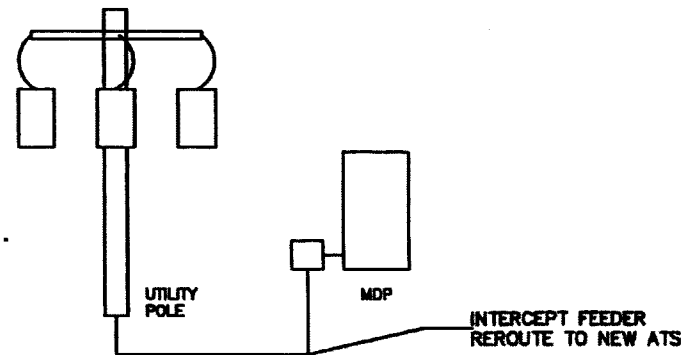

ATS IS
277/480-VOLT
400-AMP
SE RATED
N3R

CANADIAN COUNTY
ONELINE

DATE DATED
9/22/2016

PROJECT NO. 1501300-3804

DRAWN BY: CHC

CHECKED BY:

SHEET

MEP-1

PLAN VIEW:



Date Issued: October 3, 2016
Bid Number: **2017-#04**
Closing Date: October 21, 2016 at 4:00pm
PO Box 458, 201 N. Choctaw Ave., El Reno, OK 73036
Opening Date: October 24, 2016 at 9:30am
Commissioner's Meeting Room, 201 N. Choctaw Ave., El Reno, OK 73036

~ AFFIDAVIT ~
Generators / County Commissioners

State of Oklahoma)
County of Canadian) §

I, Lindsey Garrett, Purchasing Agent, in and for said County and State, do hereby certify that "Invitations to Bid" were sent to the following:

- | | | |
|--|---|--|
| Bid Clerk
projects@bidclerk.com | Bid News
projects@isqft.com | Clifford Power Systems Inc
7300 Melrose Lane
Oklahoma City, OK 73127 |
| Cummins Southern Plains LLC
PO Box 910509
Dallas, TX 75391-0509 | Elite Power Services
8001 N Classen Blvd, Suite A
Oklahoma City, OK 73118 | ePlan
4115 S. Providence, Ste. 105
Columbia, MO 65203 |
| Faith Electric Inc
6712 N Coltrane
Edmond, OK 73013 | Francis Tuttle Vo-Tech Center
Attn: Bid Assistant – Judy Robbins
12777 N. Rockwell
Oklahoma City, OK 73142 | King Electric LLC
PO Box 1367
El Reno, OK 73036 |
| Luckinbill Inc
409 W Centennial Blvd
Edmond, OK 73013 | Moisant Electric Inc
1100 SW 22nd
Oklahoma City, OK 73109 | Online Data Services
3295 River Exchange Dr, Ste. 213
Norcross, GA 30092 |
| Reed Construction Data
30 Technology Pkwy South, Ste. 100
Norcross, GA 30092 | S & W Power Systems
4100 S Eastern Avenue
Oklahoma City, OK 73129 | Sooner State Generators LLC
Attn: Steve Elias
720 W Main Street, Suite A
Collinsville, OK 74021 |
| United Engines
5555 W Reno
Oklahoma City, OK 73127 | Imajenus Incorporated
322 N Main
Broken Arrow, OK 74012 | |

Witness my hand and seal this 3rd day of October, 2016.

Kim Kaes
Kim Kaes, Assistant Purchasing Agent
(SEAL)





**Canadian County
Purchasing**

BID CHECKLIST

Date Issued: October 3, 2016
Bid Number: **2017-#04**
Closing Date: October 21, 2016 at 4:00pm
 PO Box 458, 201 N. Choctaw Ave., El Reno, OK 73036
Opening Date: October 24, 2016 at 9:30am
 Commissioner's Meeting Room, 201 N. Choctaw Ave., El Reno, OK 73036

**TO HELP PREVENT BIDS FROM BEING REJECTED FOR LACK OF COMPLETION
PLEASE CHECK FOR THE FOLLOWING:**

- Is the Invitation to Bid Signed and Notarized? _____
- Are all applicable spaces filled in? _____
- Are all necessary papers enclosed? _____
- Is the Bid # and Closing Date on outside of return envelope? _____

Thank You,

Lindsey Garrett, Purchasing Agent